



PLASTIC PACKAGE AT-STRIP SURFACE MOUNT CRYSTALS

MODEL SM1

Model	SM1
Frequency Range	3.5MHz ~ 70.0 MHz
Oscillation Mode	3.5MHz ~ 30.0MHz (AT Fundamental) 30.00MHz ~ 70.00MHz (3rd Overtone)
Frequency Tolerance@ 25°C	± 50ppm Optional Tolerances Available
Frequency Stability	± 100ppm 0°C to +70°C Standard, Optional Tolerances Available
Operating Temperature Range	-10°C ~ +60°C Standard, Optional Temperature Ranges Available
Storage Temperature Range	-55°C ~ +125°C
Equivalent Series Resistance	Resistance Specifications Below (See Chart Below)
Load Capacitance	16, 18, 20, 30, and 32pF, Custom C _L and Series resonant available
Shunt Capacitance	7pF Max
Drive Level	100μ Watts Correlation
Insulation Resistance	500 megohms Min
Aging for first year	±5ppm Max
Reflow Soldering Condition	10 Seconds Max at +235°C ±5°C

DIMENSIONS Inches (mm)

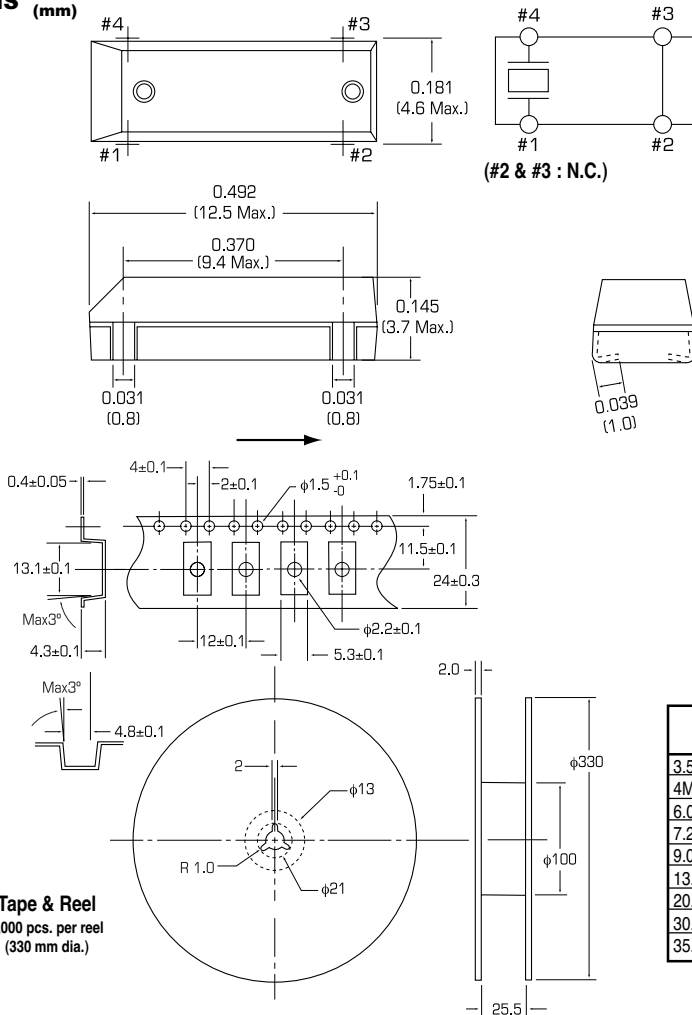

Recommended Soldering Pattern

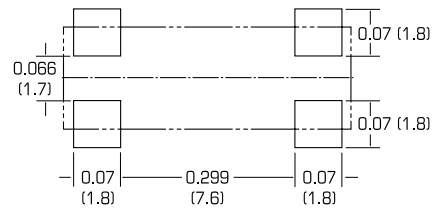

AT-CUT

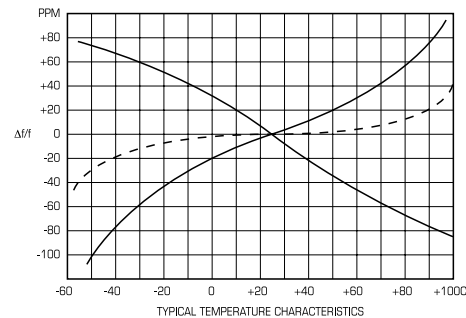

Frequency	Equivalent Series Resistance	Oscillation Mode
3.5MHz ≤ f ₀ < 4MHz	200Ω Max	Fundamental
4MHz ≤ f ₀ < 6.000MHz	150Ω Max	Fundamental
6.000MHz ≤ f ₀ < 6.50MHz	100Ω Max	Fundamental
7.25MHz ≤ f ₀ < 8.000MHz	80Ω Max	Fundamental
9.00MHz ≤ f ₀ < 13.00MHz	60Ω Max	Fundamental
13.50MHz ≤ f ₀ < 19.6608MHz	50Ω Max	Fundamental
20.00MHz ≤ f ₀ < 29.491MHz	40Ω Max	Fundamental
30.00MHz ≤ f ₀ < 33.868MHz	100Ω Max	Fundamental
35.251MHz ≤ f ₀ < 80.000MHz	100Ω Max	3rd Overtone