

- WLAN, RF SAW Filter
- Revision 0: August 2012

Electrical Characteristics

MAXIMUM RATING				
PARAMETERS DESCRIPTION	UNIT	MINIMUM	TYPICAL	MAXIMUM
Operating Temperature Range	°C	-30	-	+85
Storage Temperature Range	°C	-40	-	+85
Maximum DC Voltage	V	-	-	0
Maximum Input Power	dBm	-	-	10
Source Impedance (single ended) ⁽¹⁾	Ω	-	50	-
Load Impedance (single ended) ⁽¹⁾	Ω	-	50	-
Package type & size	a2			
Length x Width	mm ²	-	1.1 x 0.9	-
Height	mm	-	-	0.5

ELECTRICAL SPECIFICATION				
PARAMETERS DESCRIPTION	UNIT	MINIMUM	TYPICAL	MAXIMUM
Center Frequency (Fo)	MHz	-	2450.0	-
Max.Insertion Loss within 2400.0~2500.0 MHz	dB	-	1.5	2.5
Amplitude Ripple within 2400.0~2500.0 MHz	dB _{p-p}	-	0.55	1.5
Attenuation:				
D.C ~ 960.0 MHz	dB	35	53	-
960.0 ~ 1570.0 MHz	dB	35	45	-
1570.0 ~ 1580.0 MHz	dB	35	45	-
1580.0 ~ 1710.0 MHz	dB	35	43	-
1710.0 ~ 1910.0 MHz	dB	33	38	-
1910.0 ~ 1980.0 MHz	dB	35	42	-
2110.0 ~ 2170.0 MHz	dB	28	32	-
2640.0 ~ 3000.0 MHz	dB	20	25	-
3000.0 ~ 4800.0 MHz	dB	15	20	-
4800.0 ~ 5000.0 MHz	dB	15	19	-
5000.0 ~ 6000.0 MHz	dB	15	18	-
VSWR within 2400.0~2500.0 MHz	-	-	1.9	2.3

Notes: (1) With Matching Network (Ref. Testing Environment Circuit as shown below).

Package Dimensions

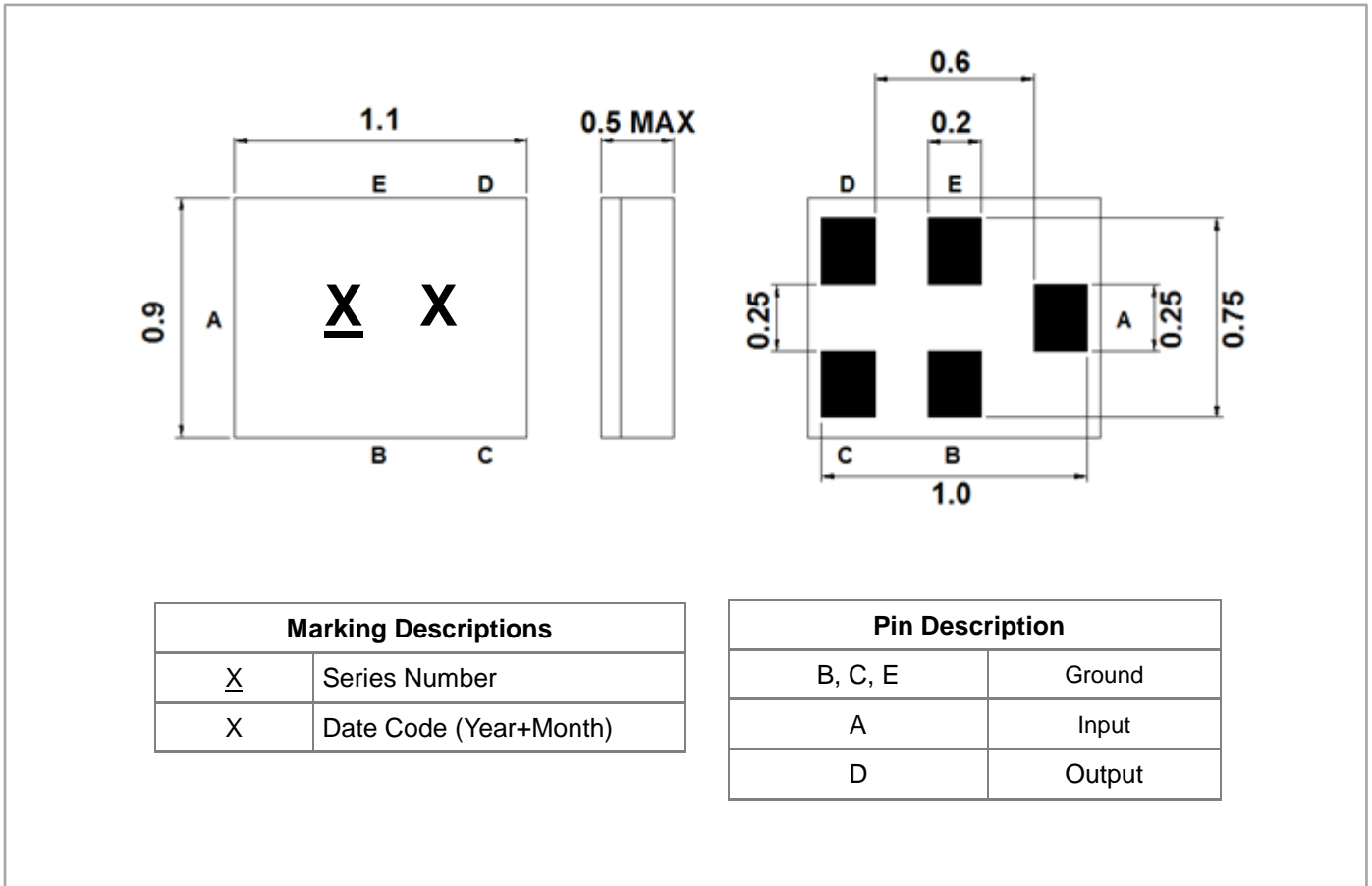

Testing Environment

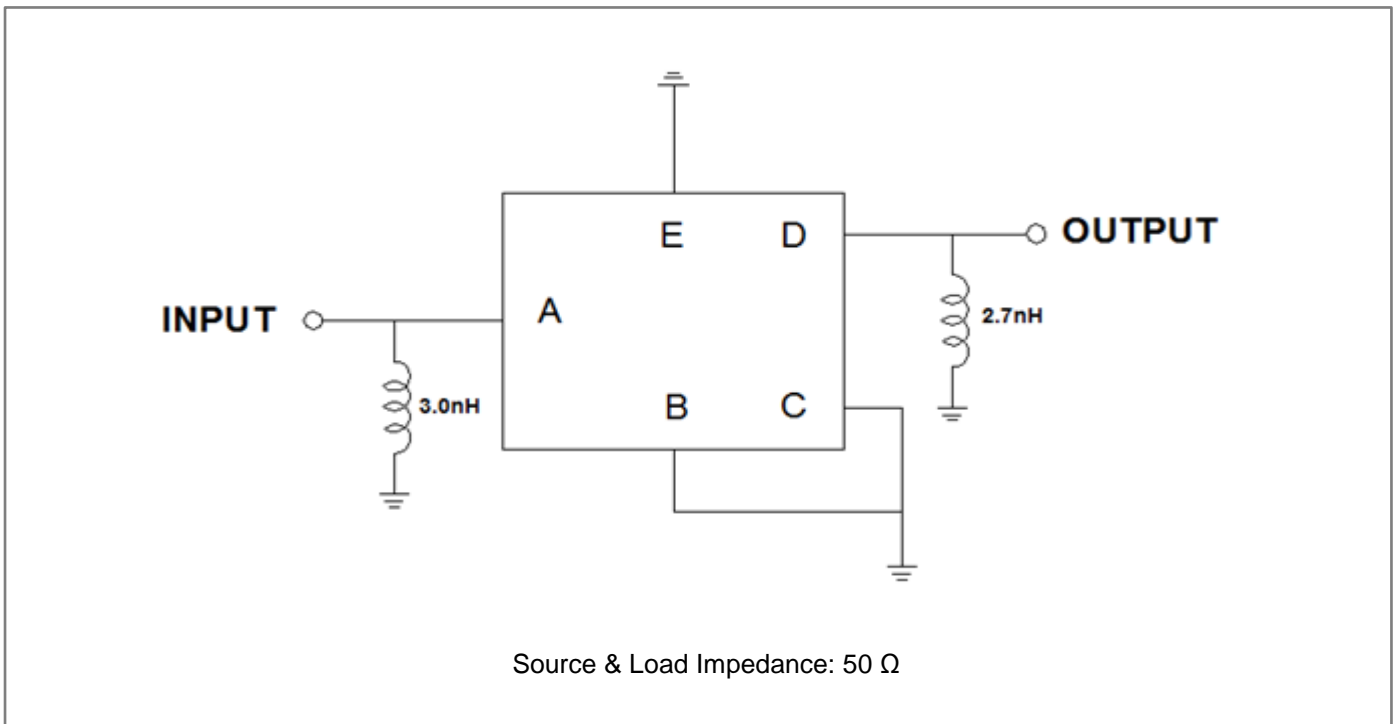

Frequency Characteristics

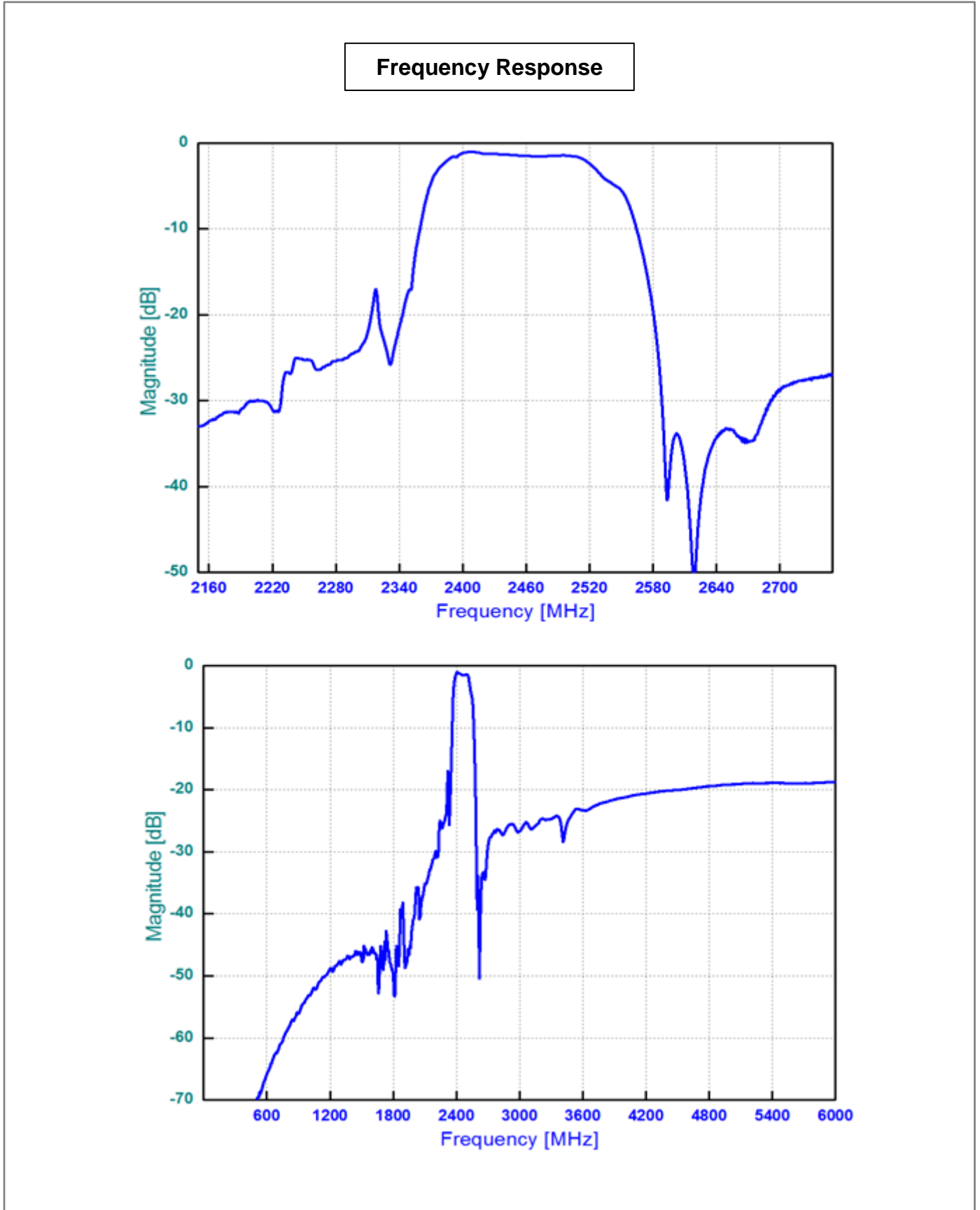

VSWR

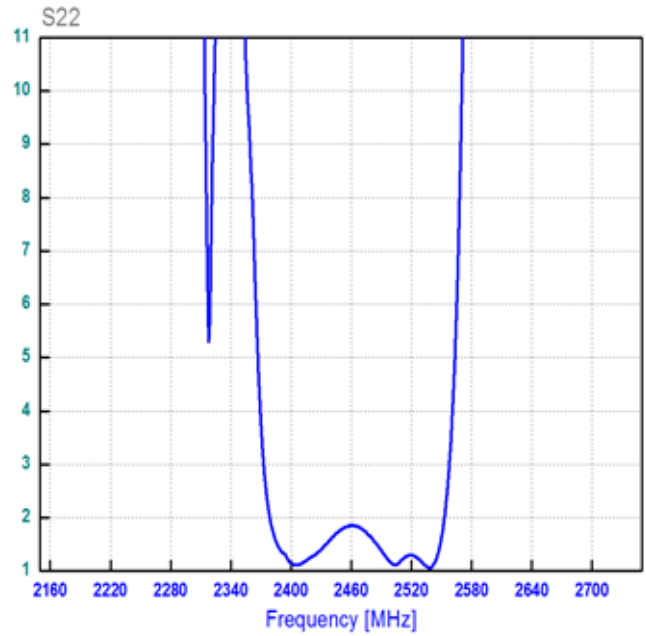
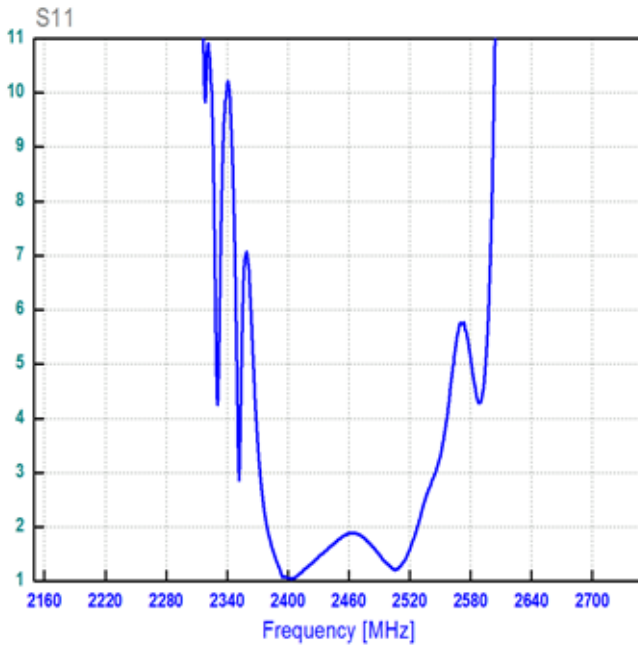

Smith Chart

