

- GPS RF SAW Filter
- Revision 0: December 2011

Electrical Characteristics

MAXIMUM RATING				
PARAMETERS DESCRIPTION	UNIT	MINIMUM	TYPICAL	MAXIMUM
Operating Temperature Range	°C	-40	-	+85
Storage Temperature Range	°C	-40	-	+85
Maximum DC Voltage	V	-	-	3
Maximum Input Power	dBm	-	-	15
Source Impedance (single ended) ⁽¹⁾	Ω	-	50	-
Load Impedance (single ended) ⁽¹⁾	Ω	-	50	-
Package type & size	Q3			
Length x Width	mm ²	-	1.4 x 1.1	-
Height	mm	-	-	0.6

ELECTRICAL SPECIFICATION				
PARAMETERS DESCRIPTION	UNIT	MINIMUM	TYPICAL	MAXIMUM
Center Frequency (Fo)	MHz	-	1575.42	-
Max.Insertion Loss within 1574.42~1576.42 MHz	dB	-	0.9	1.5
Amplitude Ripple within 1574.42~1576.42 MHz	dB _{p-p}	-	0.1	0.75
2dB Bandwidth	MHz	-	40	-
Attenuation:				
D.C. ~ 1450.0 MHz	dB	35	38	-
1450.0 ~ 1520.0 MHz	dB	30	45	-
1625.0 ~ 1640.0 MHz	dB	45	48	-
1640.0 ~ 1805.0 MHz	dB	38	40	-
1805.0 ~ 1910.0 MHz	dB	38	40	-
1910.0 ~ 2000.0 MHz	dB	38	43	-
2000.0 ~ 4000.0 MHz	dB	30	45	-
4000.0 ~ 6000.0 MHz	dB	20	22	-
VSWR within 1574.42~1576.42 MHz	-	-	1.15	1.6

Notes: (1) No Matching Network (Ref. Testing Environment Circuit as shown below).

Package Dimensions

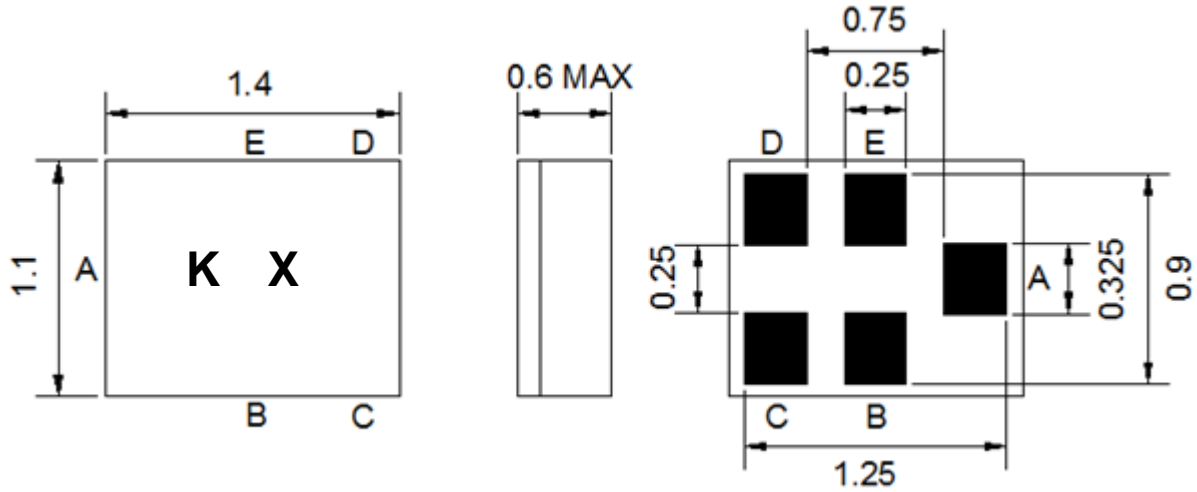

Marking Descriptions	
K	Series Number
X	Date Code (Year+Month)

Pin Description	
B, C, E	Ground
A	In
D	Out

Testing Environment

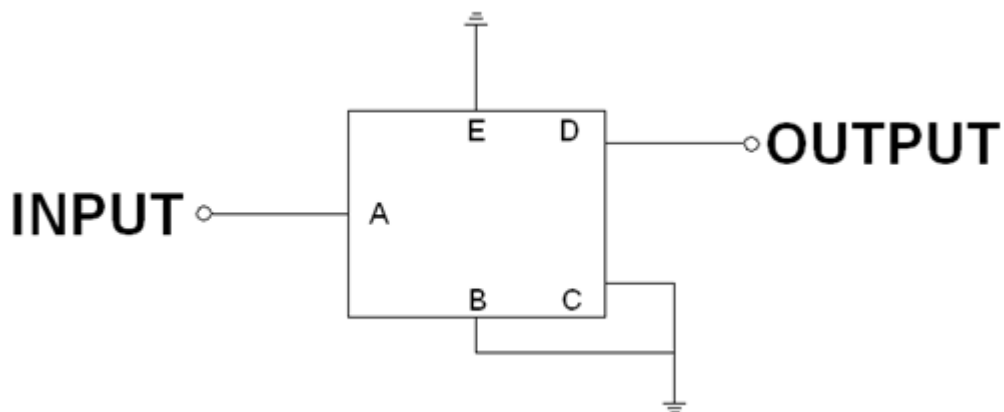

Source & Load Impedance: 50 Ω

Frequency Characteristics

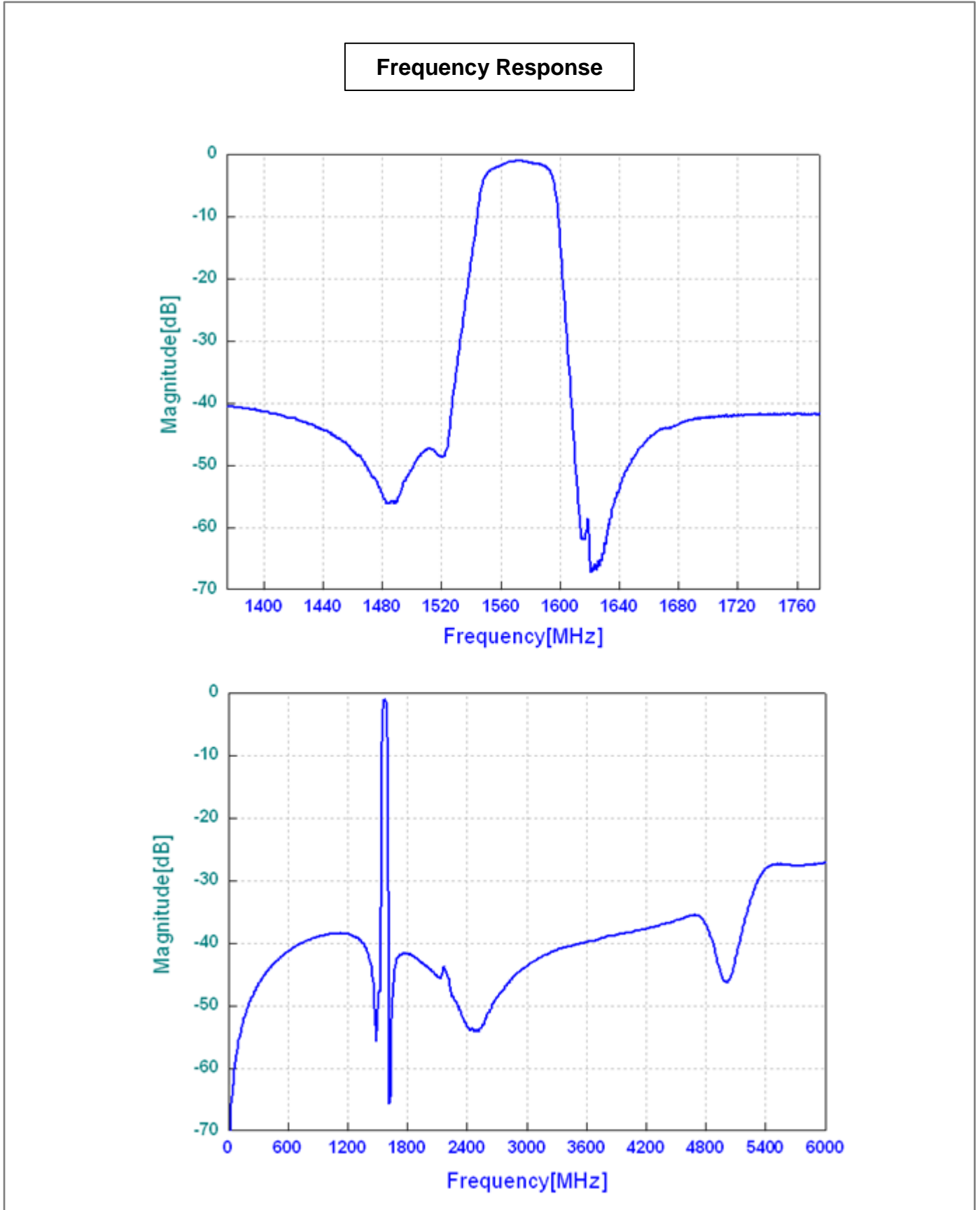

VSWR

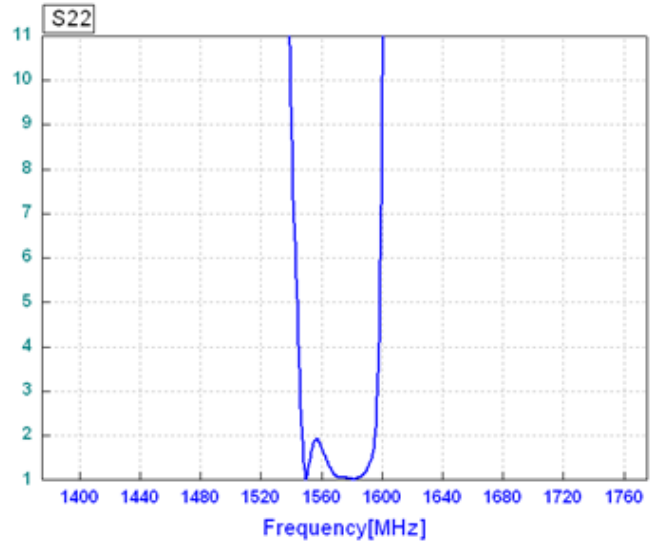
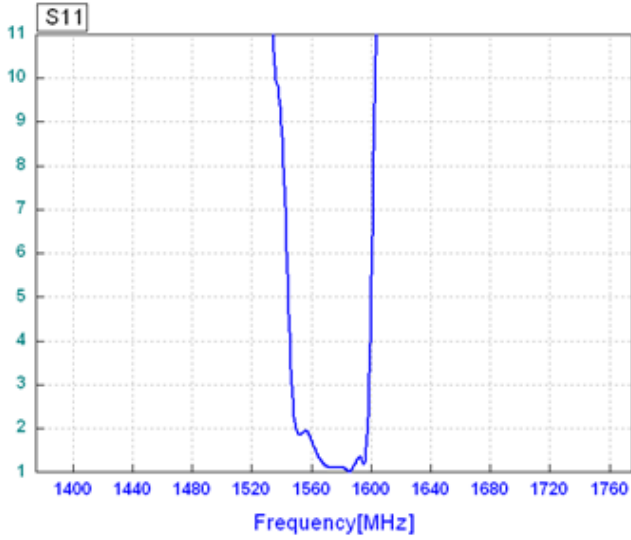

Smith Chart

