

- Wireless, RF SAW Filter
- Revision 0: July 2010

Electrical Characteristics

MAXIMUM RATING				
PARAMETERS DESCRIPTION	UNIT	MINIMUM	TYPICAL	MAXIMUM
Operating Temperature Range	°C	-40	-	+85
Storage Temperature Range	°C	-40	-	+85
Maximum DC Voltage	V	-	-	-
Maximum Input Power	dBm	-	-	10
Source Impedance (single ended) ⁽¹⁾	Ω	-	50	-
Load Impedance (single ended) ⁽¹⁾	Ω	-	50	-
Package type & size	P1			
Length x Width	mm ²	-	3.8 x 3.8	-
Height	mm	-	-	1.4

ELECTRICAL SPECIFICATION				
PARAMETERS DESCRIPTION	UNIT	MINIMUM	TYPICAL	MAXIMUM
Center Frequency (Fo)	MHz	-	1234.4	-
Insertion Loss within 1211.9 ~ 1256.9 MHz	dB	-	1.9	3.8
Amplitude Ripple within 1211.9 ~ 1256.9 MHz	dB _{p-p}	-	1.0	2.0
Group Delay Variation within 1211.9 ~ 1256.9 MHz	ns _{p-p}	-	15	30
Attenuation:				
950.0 ~ 1088.0 MHz	dB	20	25	-
1088.0 ~ 1178.0 MHz	dB	20	24	-
1297.0 ~ 1387.0 MHz	dB	20	23	-
1387.0 ~ 1534.0 MHz	dB	17	21	-

Notes: (1) With Matching Network

Package Dimensions

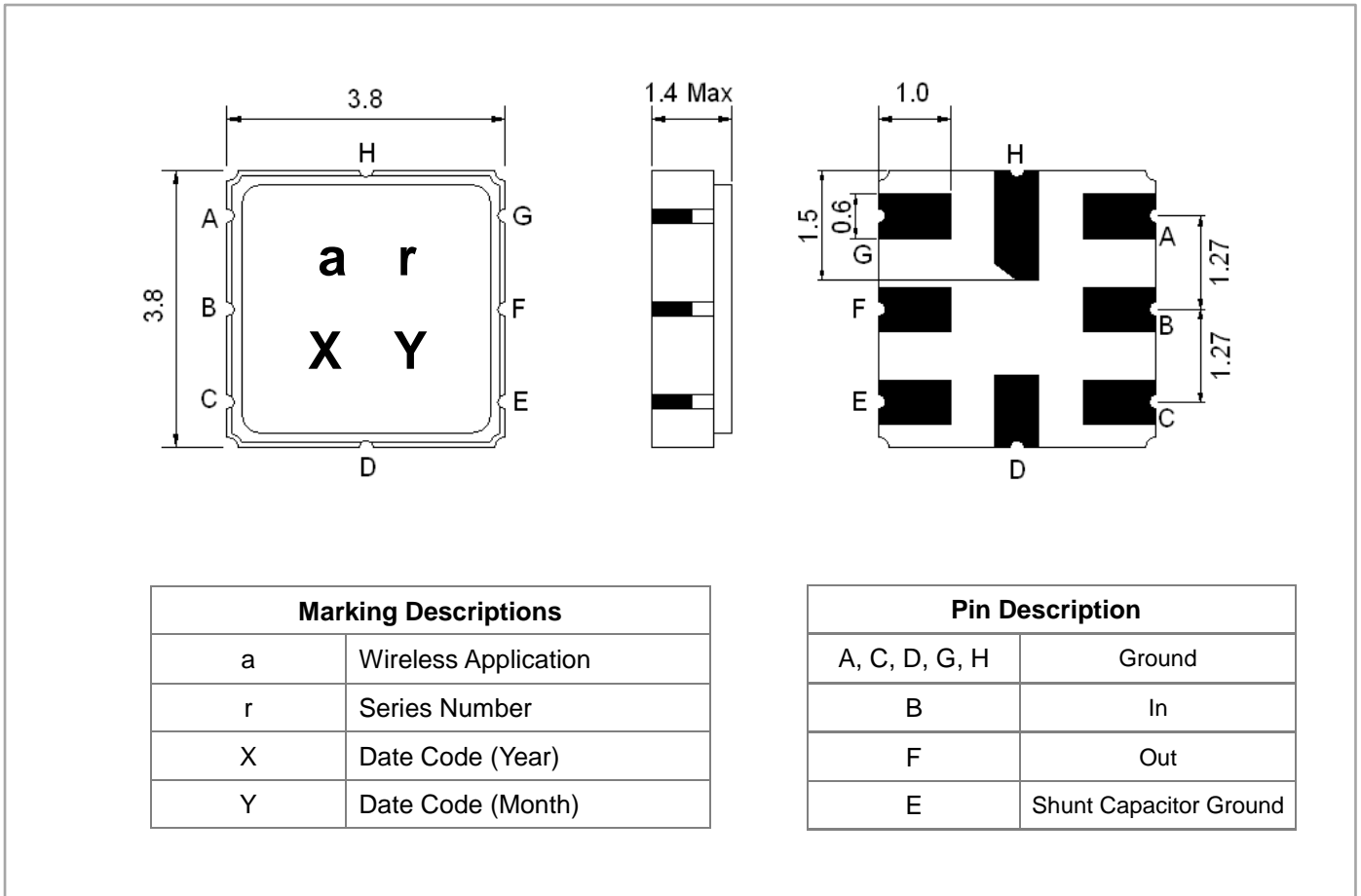

Testing Environment

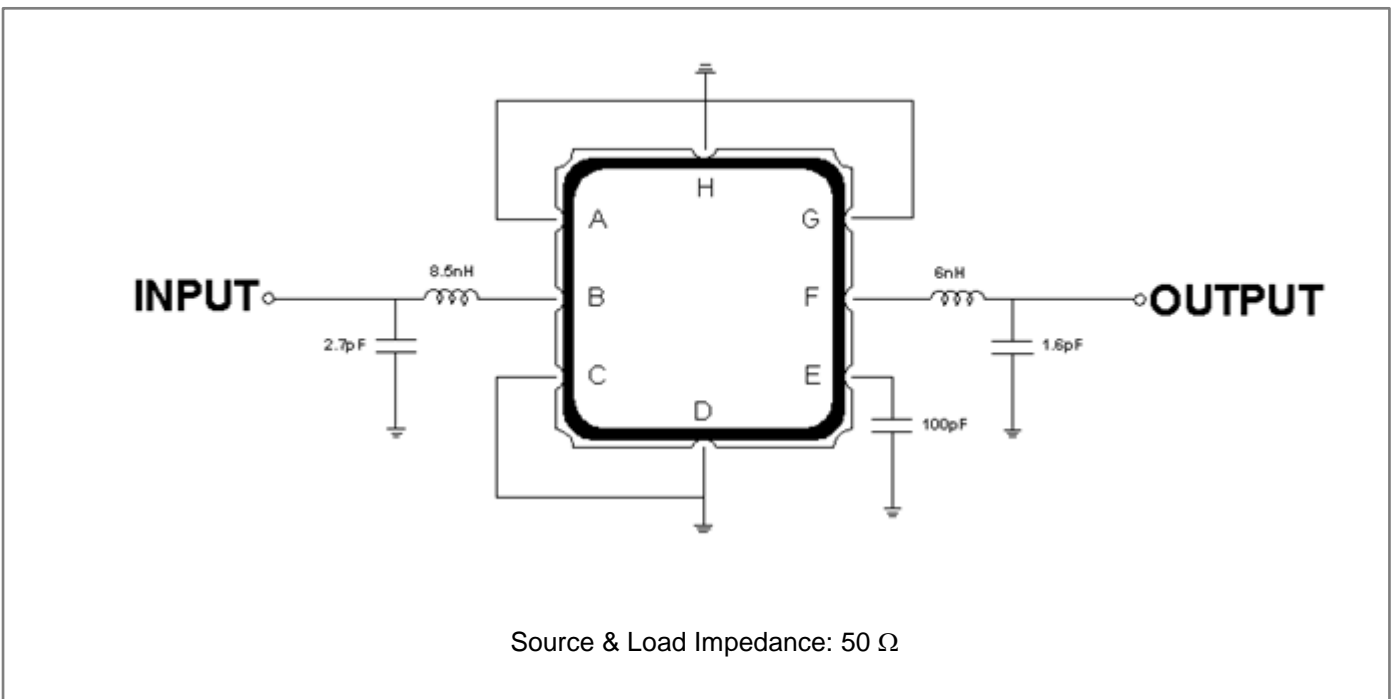

Frequency Characteristics

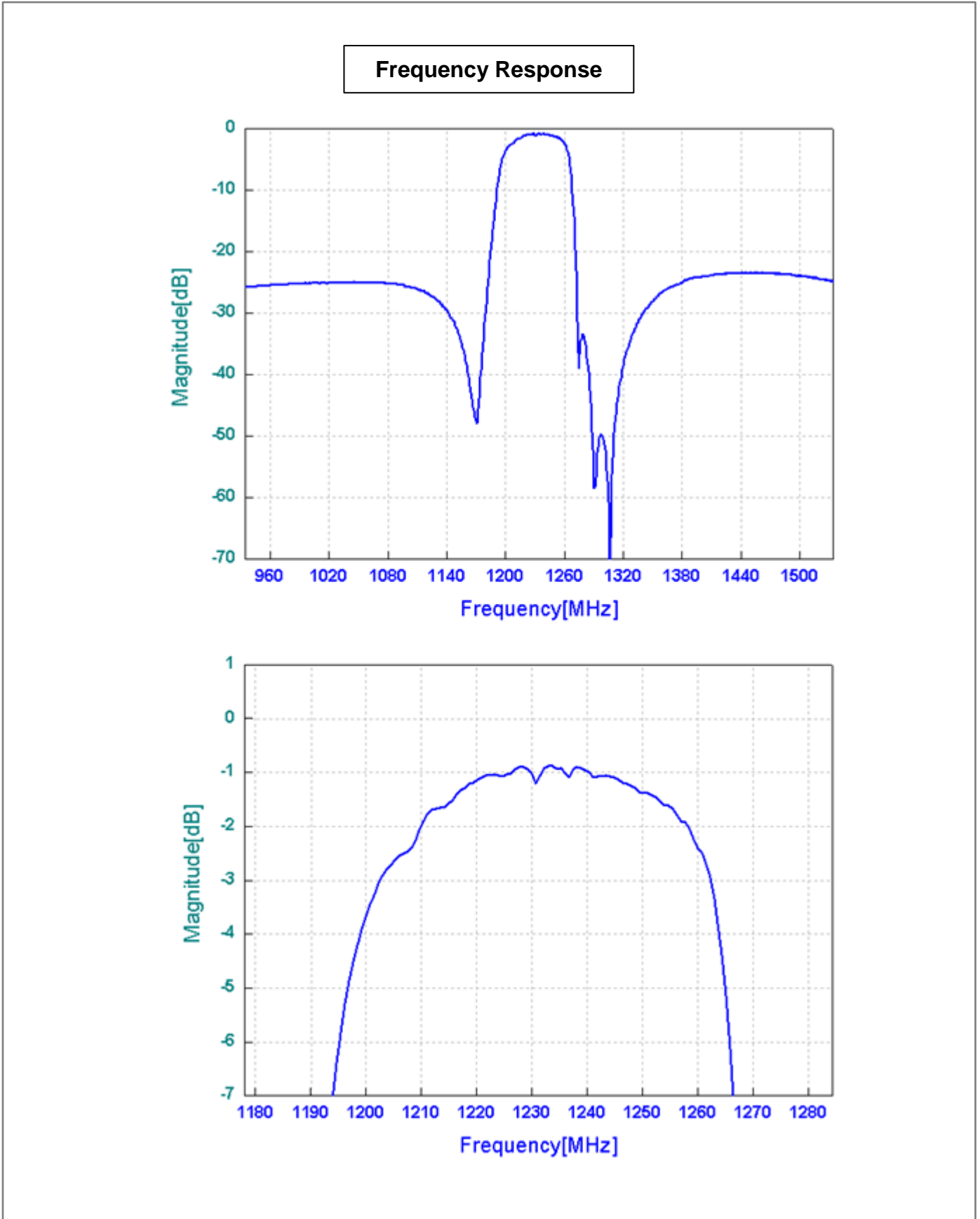

Group Delay

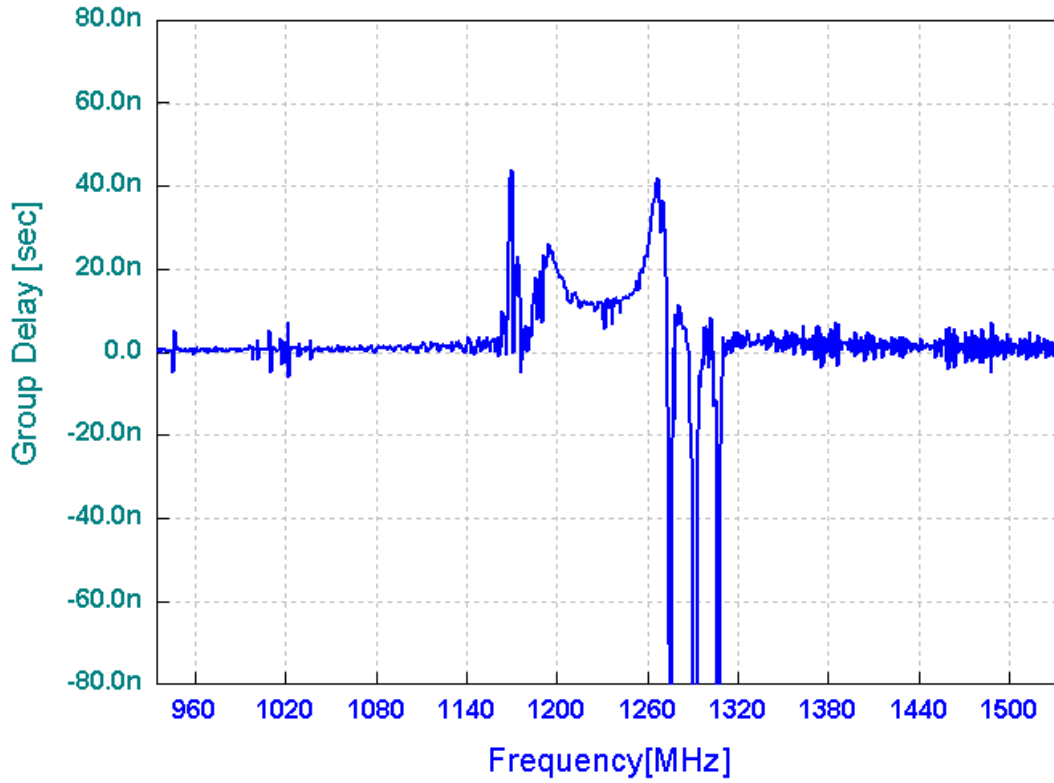

Smith Chart

