

- SAW Duplexer For 751MHz / 781MHz
- Revision 0: November 2008

## Electrical Characteristics

MAXIMUM RATING				
PARAMETERS DESCRIPTION	UNIT	MINIMUM	TYPICAL	MAXIMUM
Operation Temperature Range	°C	-30	-	+85
Storage Temperature Range	°C	-40	-	+85
Maximum DC Voltage	V	-	0	-
Tx Band Input Power Level within 777~ 787 MHz	dBm	30dBm > 50000 Hours, CW tone(Ta=+50°C)		
Ant. Tx. Rx Terminating Impedance	Ω	-	50	-
Package type	P3			
Length x Width	mm <sup>2</sup>	-	3.8 x 3.8	-
Height	mm	-	-	1.45

ELECTRICAL SPECIFICATION					
PARAMETERS	CONDITION [MHZ]	UNIT	MINIMUM	TYPICAL	MAXIMUM
Tx_781MHz		Specifications			
Insertion Loss	777~ 787	dB	-	1.8	2.5
Ripple	777~ 787	dB <sub>p-p</sub>	-	0.6	1.2
VSWR	777~ 787	-	-	1.7	2.2
Absolute Attenuation	1 ~ 746	dB	37	42	-
	746 ~ 756	dB	45	48	-
	758 ~ 768	dB	10	20	-
	869 ~ 894	dB	40	49	-
	1574.42 ~ 1576.42	dB	40	48	-
	2328 ~ 2361	dB	30	41	-
3104 ~ 3148	dB	25	30	-	-
Rx_751MHz		Specifications			
Insertion Loss	746 ~ 756	dB	-	1.5	2.5
Ripple	746 ~ 756	dB <sub>p-p</sub>	-	0.4	1.2
VSWR	746 ~ 756	-	-	1.5	2.2
Absolute Attenuation	1 ~ 716	dB	35	41	-
	716 ~ 728	dB	40	50	-
	777 ~ 787	dB	50	60	-
	787 ~ 849	dB	38	44	-
	1710 ~ 1755	dB	40	46	-
	1850 ~ 1920	dB	35	45	-
Rx → Tx		Specifications			
Isolation	777 ~ 787	dB	55	60	-
	746 ~ 756	dB	50	55	-

**\*Note :** Including losses due to Test PCB(0.3dB)

## Package Dimensions

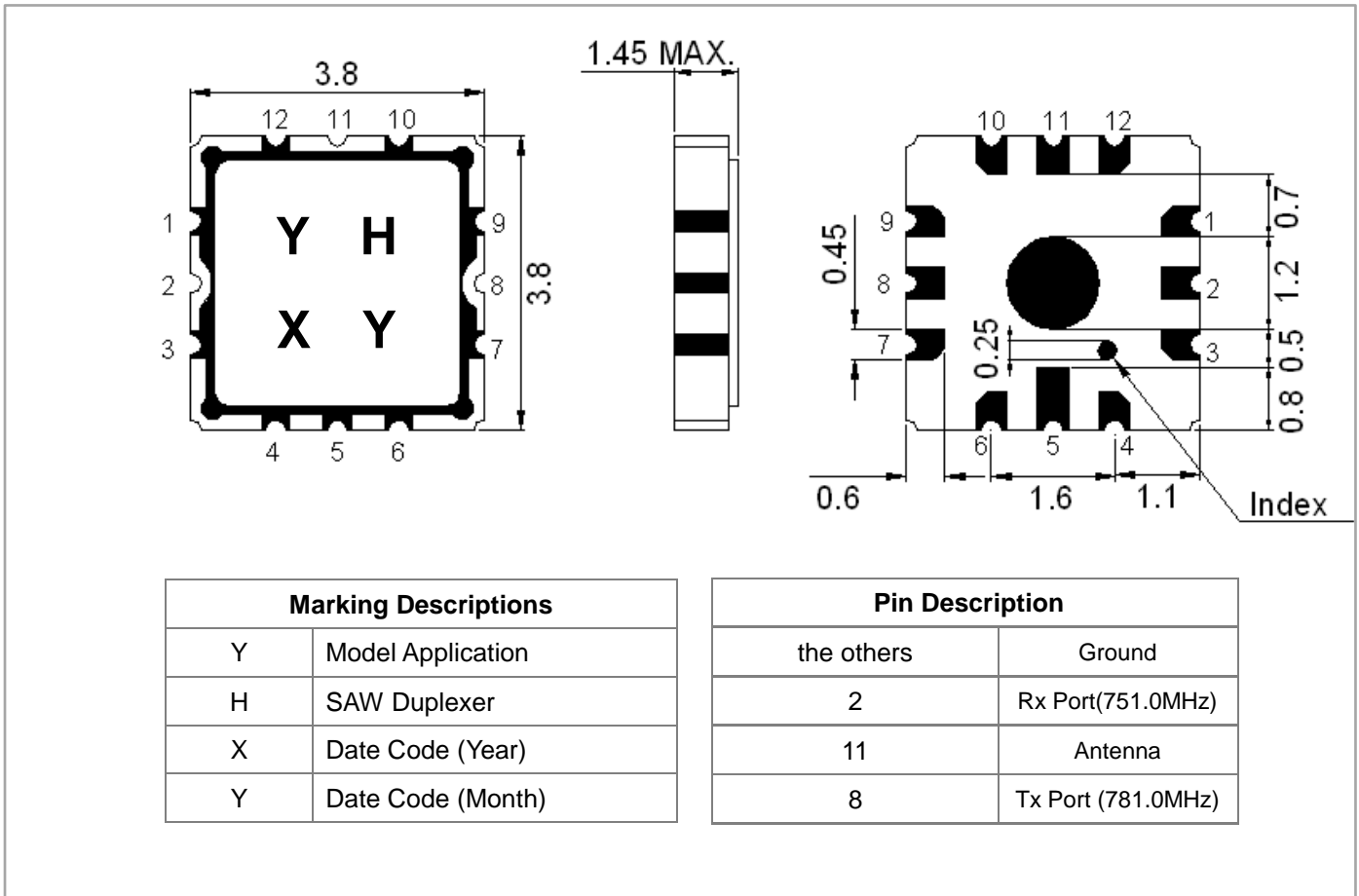

## Testing Environment

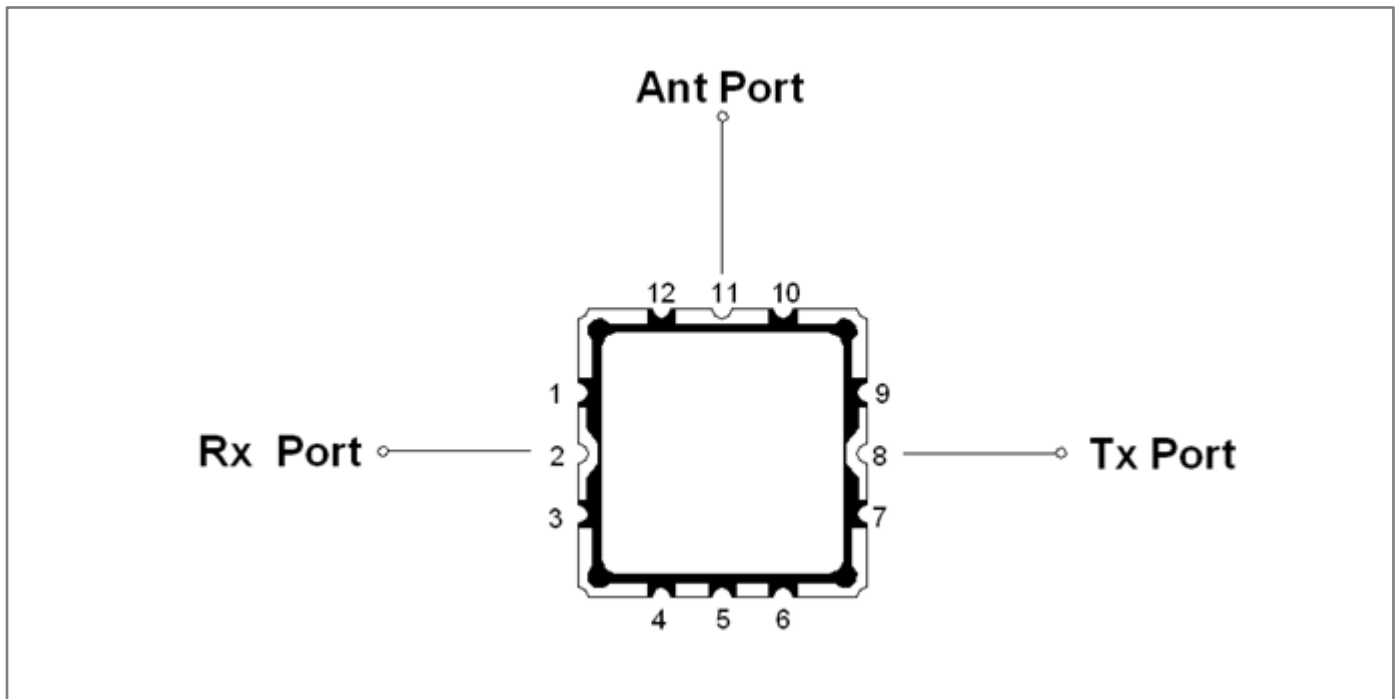

## Frequency Characteristics

**Rx Characteristic**

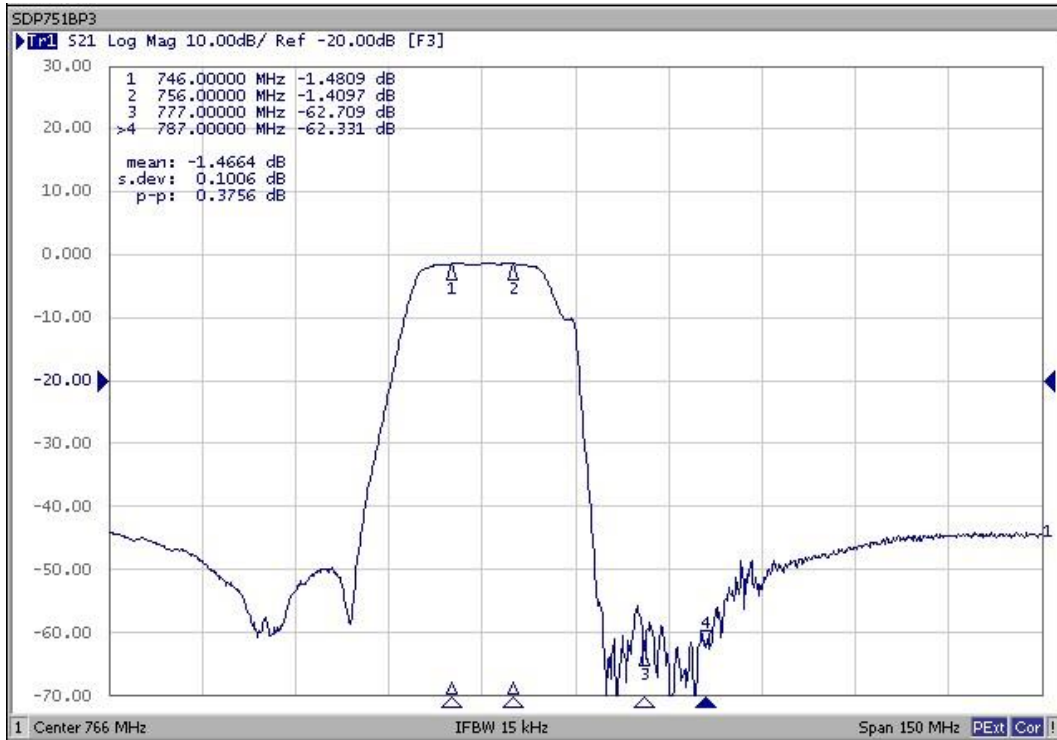

**Tx Characteristic**

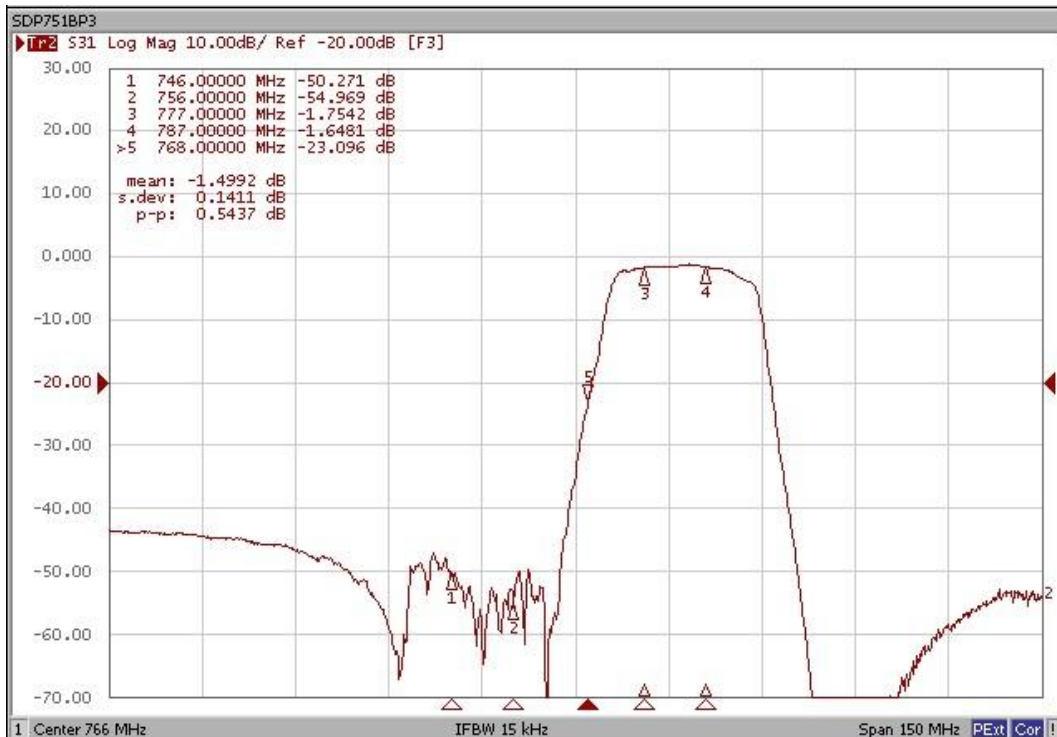

## Isolation

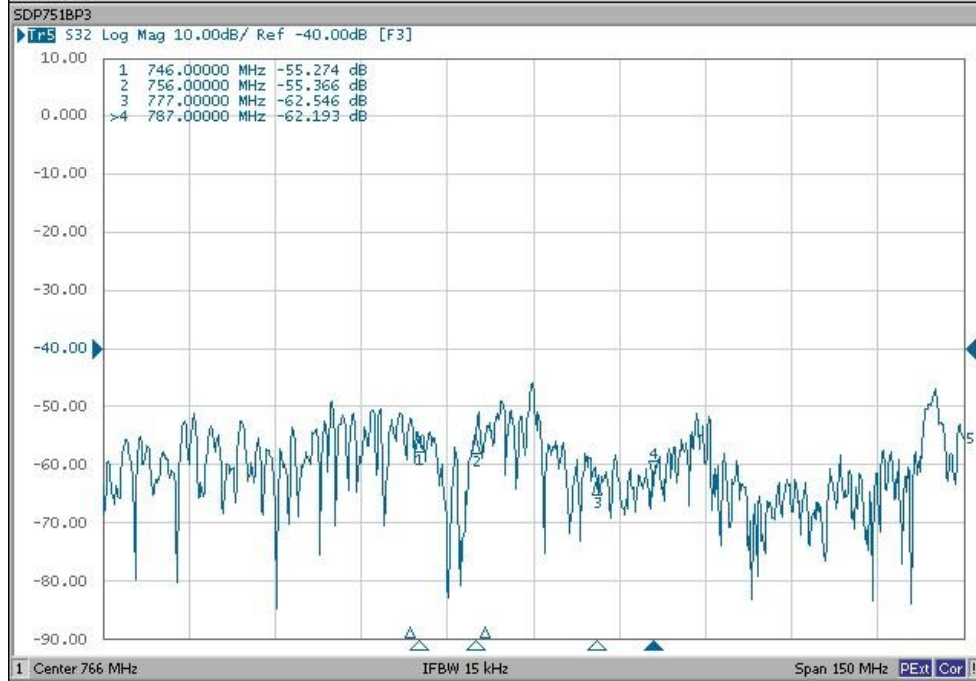

**VSWR & SmithChart Characteristic**

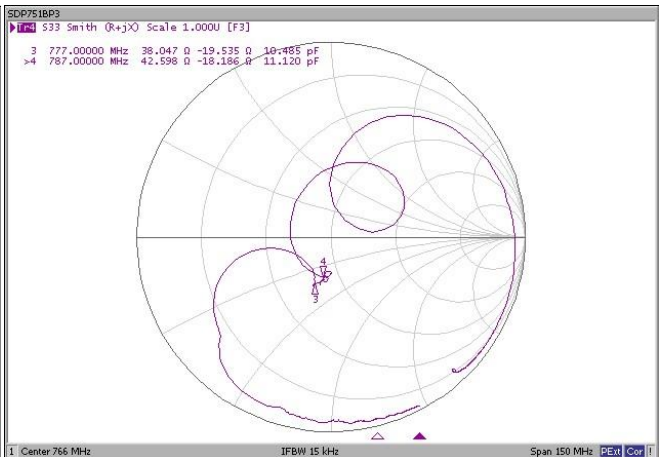
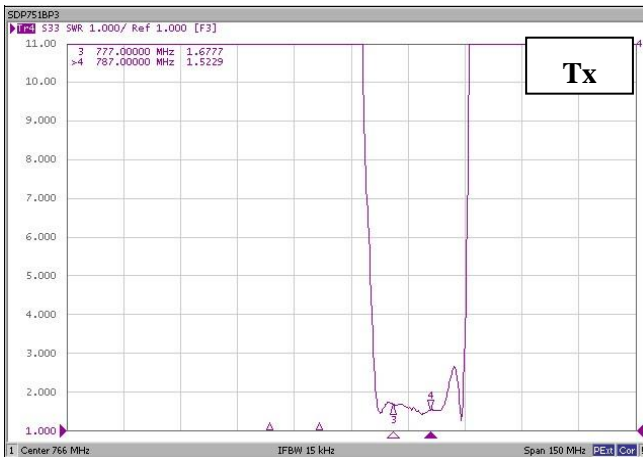
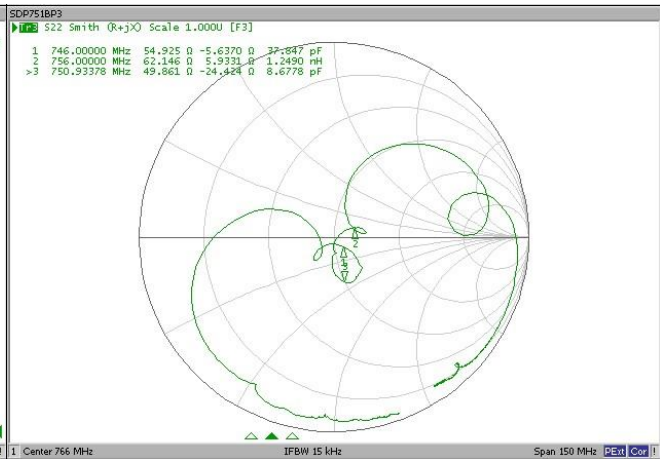
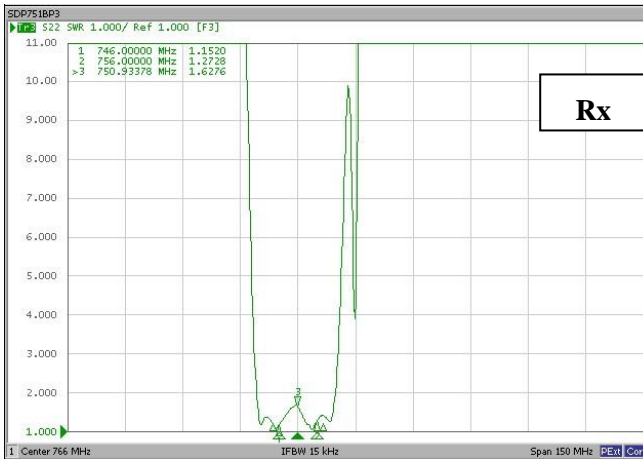
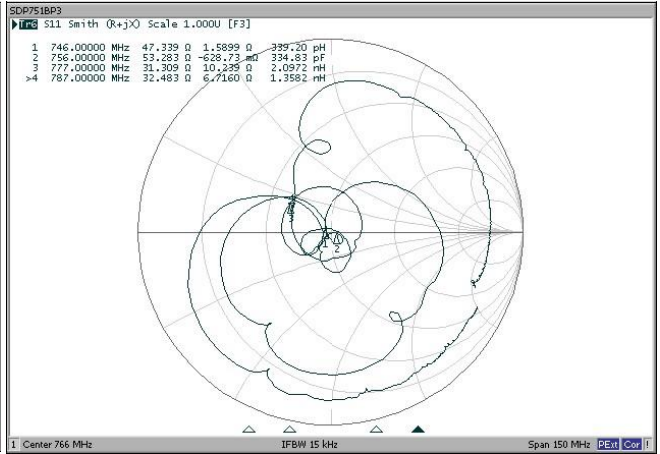
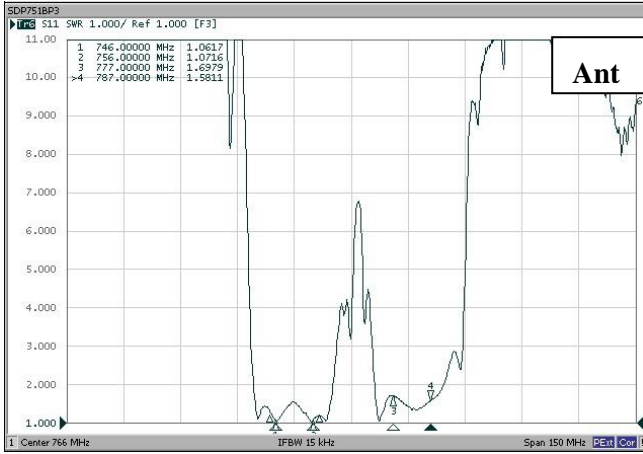

**Wide Span Characteristic**

